

NEW SPEED-LOCK FILTER VESSELS FOR EFFICIENTLY REMOVING PARTICLES AND CONTAMINANTS FROM LIQUIDS

THE FTS SPEED-LOCK CLOSURE is a new quick release lid mechanism designed for both Bag and Cartridge Pressure Filter Vessels. The hinged retaining ring, with a safety latch, secures the lid circumference against leakage while operating under pressure. Integrating the locking device with the filter vessel lid makes bag and cartridge changes fast and easy.



THE BAG MODELS:

As the lid is closed, the bail of the filter support basket acts as a spring. Then the lid is in a closed position, the bail is in contact with the lid, as the Speed-Lock is engaged, a downward movement is imparted against an "O" Ring located in a groove in the filter basket flange. This action seals the filter basket against particle migration around the filter bag.

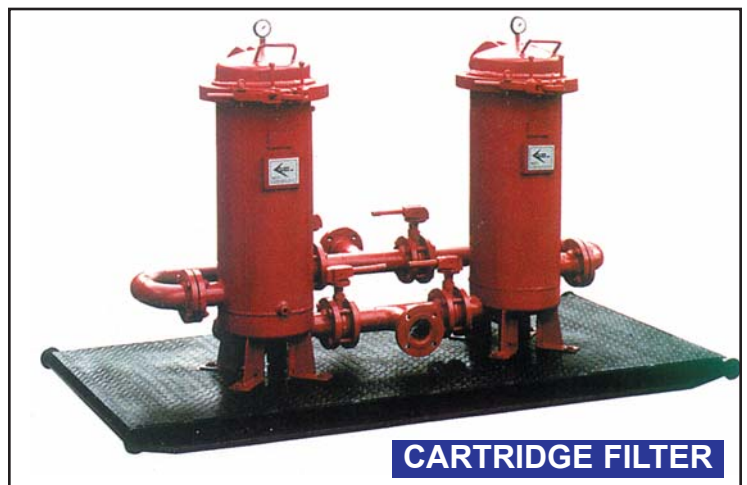
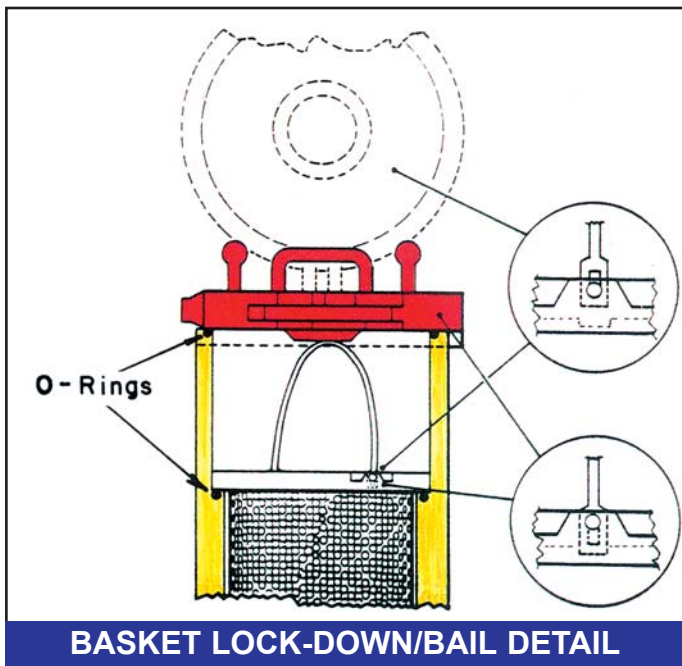

For more information concerning this system, please contact:



707 Lehman
Houston, TX 77018
Telephone (713) 699-0152
Fax (713) 699-8054
www.flotrend.com
flotrend@flotrend.com

FLO TREND SYSTEMS, INC.
HOUSTON, TEXAS

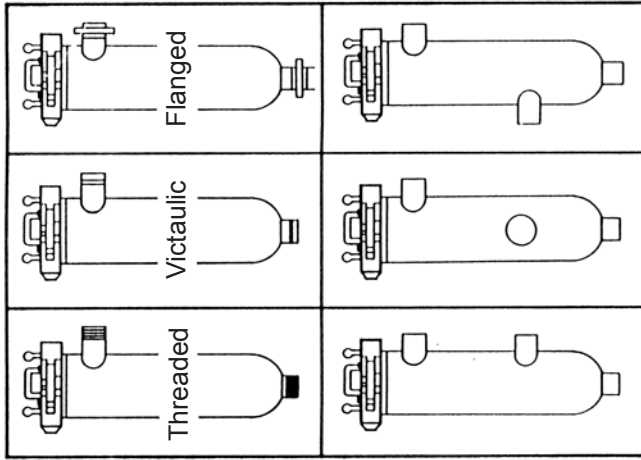
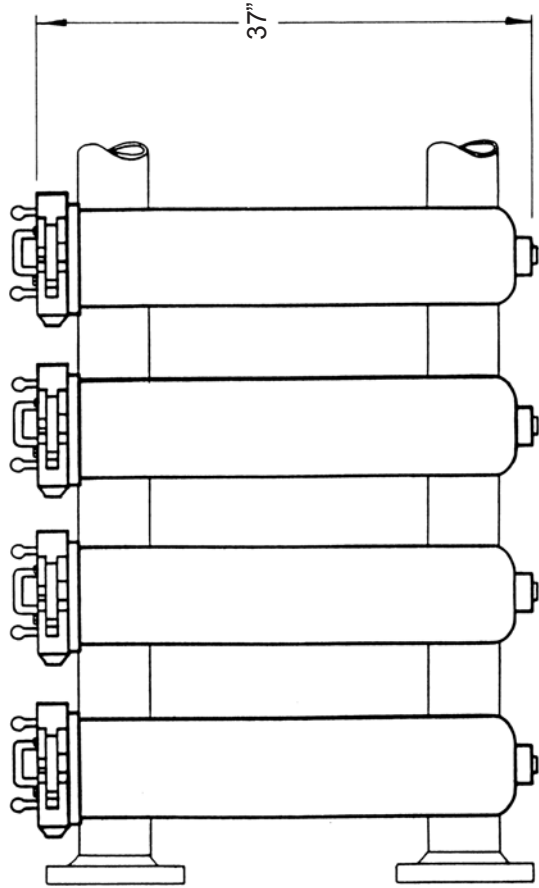
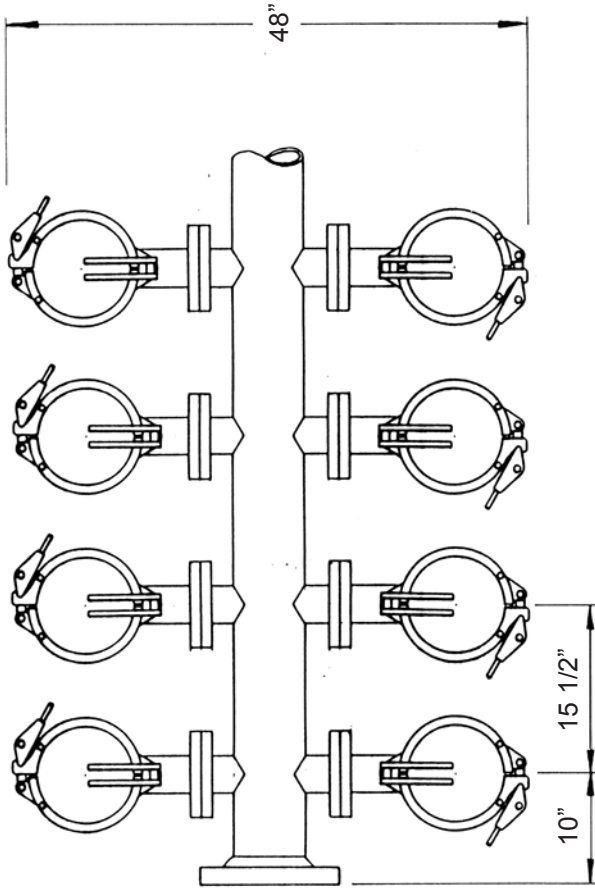

FLO TREND
SYSTEMS, INC.

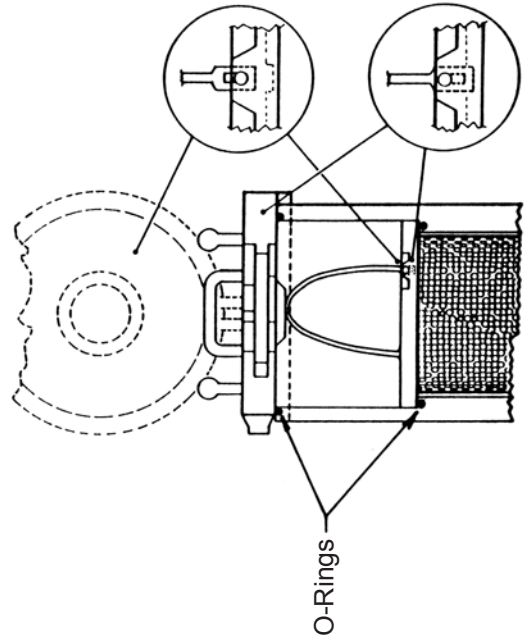

Basket Lock-Down / Ball Detail